

AdventistSat Installation Guide

Fortec Mercury II

v.6 4.29.2008



AdventistSat.com
Adventist Satellite Ministry Support Services

Tel 916-677-0720 • Fax 916-677-6228
8801 Washington Blvd., Ste. 101, Roseville, CA 95678

<http://www.adventistsat.com>



Satellite System for Reception of Satellite AMC4

Important Notice: Your equipment must be activated before installation. Please follow the simple activation process on page 23 of this manual.

Professional Installers:
Quick Install Guide on Pages 34 - 36

Important Notice: Your equipment must be activated before installation. Please follow the simple activation process on page 23 of this manual.

Important Installation Notice: The Federal Communications Commission (FCC) has ruled that local government zoning or homeowner's associations may not prevent the installation of satellite antennas one meter (39") or smaller in diameter, unless legitimate safety restrictions such as fire codes are in effect.

For more information: www.fcc.gov/cgb/satellite.html

Table of Contents	AdventistSat V.101	Page
Parts List		4
Important Safeguards		5
Site Survey		10
Dish Assembly		14
Universal Post Mount Assembly and Install		18
Dish Aiming Angles		20
Connect Receiver and Television		22
Activate Preprogrammed Channels		23
Locate Satellite and Peak Signal Quality		24
Grounding the System		27
Basic Operation		28
Frequently Asked Questions		29
Connection Examples		31
Accessories		32
Limited Warranty		33
Quick Install Guide for Professional Installers		34
Site Check: Elevation Finder Tool		37

Note: Save all original boxes, manuals, accessories and packaging materials in case it is necessary to return the merchandise. You have 30 days from the date of delivery to return the equipment for refund or exchange to AdventistSat.

Before unpacking or assembly of any item, review the warranty, exchange and refund policy on page 33 of this manual.

Please call 866-552-6882 with any questions.

Materials contained in this installation manual are the property of:

AdventistSat.com

8801 Washington Blvd., Suite 101

Roseville, CA 95678

www.adventistsat.com

©2008 AdventistSat.com

The receiver has a serial number located on the rear panel. Record the model and serial numbers and retain for your records.

Model Name or Number _____

Serial number _____



AdventistSat requires that you carefully read through these pages before beginning the installation.

This guide is intended for an individual experienced in performing the various tasks described, including:

- Determining an antenna location with a view of the satellites positions.
- Climbing a ladder and working on your roof.
- Observing safe working practices around heights and electrical hazards.
- Determining if water pipes, gas lines or wires are hidden before drilling.
- Using a power drill to drill holes into your house.
- Routing cable through walls, crawl spaces or attics.
- Safely lifting and securing the 25 lb. antenna assembly.
- Grounding the system as recommended in the National Electric Code.

NOTE: If you don't feel completely comfortable with these tasks, please contact AdventistSat toll free at 866-552-6882 or local 916-677-6228 for information on having your system installed by a local installer.

Local installers that are experienced with the installation of Free to Air satellite equipment are often available and listed in your local telephone directory Yellow Pages or on our Free Installer Referral Website <http://www.FTAinstall.com>. There also may be members of your local church or community that install these systems as an outreach.

Deluxe AdventistSat Satellite System Parts



Reflector (1)



LNB ARM (1)



Post (1)



Tripod Support Leg (2)



LNB Arm Supports (2)



Installation Kit (1)



Dish Accessory Kit (1)



Satellite Receiver (1)



LNB (1)

Tools Required



10, 11mm Socket



Measuring Tape



Phillips Screwdriver



Drill and Bits



Hammer



Important Safeguards



The lightning flash with arrowhead symbol within a triangle is intended to alert the user to the presence of uninsulated “dangerous voltage” within the product’s enclosure—voltage that may be of sufficient magnitude to constitute a risk of electrical shock.



The exclamation point within a triangle is intended to alert the user to the presence of *important* operational and maintenance (servicing) instructions in the literature accompanying the appliance.

WARNING: To reduce the risk of fire or electrical shock, do not expose your receiver to rain or moisture.

CAUTION: Do not remove cover. No user serviceable parts are inside. Please refer servicing to qualified service personnel only.

Note: Hardware / software modifications not expressly authorized by AdventistSat will void any system warranty.

CAUTION: To prevent electric shock, do not use your receiver’s (polarized) plug with an extension cord receptacle or other outlet unless the blades can be fully inserted to prevent blade exposure.

Notice to System Installer: This is a reminder to the system installer to follow Article 820-40 of the NEC that provides guidelines for proper grounding and, in particular, specifies that the cable ground shall be connected to the grounding system of the building, as close to the point of cable entry as practical.

Example of Antenna Grounding

NEC, ANSI/NFPA 70

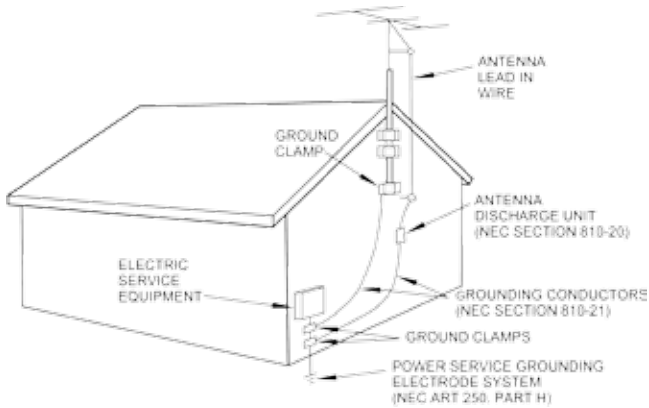

CAUTION: Read all of these Instructions. Save these Instructions for later use. Follow all Warnings and Instructions marked on the equipment.

Read Instructions All the safety and operating instructions should be read before the product is operated.

Retain Instructions The safety and operating instructions should be retained for future reference.

Heed Warnings All warnings on the product and in the operating instructions should be adhered to.

Follow Instructions Follow all operating and usage instructions.

Cleaning Unplug this product from the wall outlet before cleaning. Do not use liquid cleaners or aerosol cleaners. Use a damp cloth for cleaning.

Attachments Do not use attachments not recommended by the product manufacturer as they may cause hazards.

Water and Moisture Do not use this product near water. For example, near a bath tub, wash bowl, kitchen sink, or laundry tub; in a wet basement, near a swimming pool, etc.



Accessories Do not place this product on an unstable cart, stand, tripod, bracket, or table. The product may fall, causing serious injury to a child or adult, and serious damage to the product. Use only with a suitable cart, stand, tripod, bracket, or table.

Any mounting of the product should follow the manufacturer's instructions, and should use a mounting accessory recommended by the manufacturer. A product and cart combination should be moved with care. Quick stops, excessive force, and uneven surfaces may cause the product and cart combination to overturn.

Ventilation Slots and openings in the cabinet are provided for ventilation and to ensure reliable operation of the product and to protect it from overheating. These openings must not be blocked or covered. The openings should never be blocked by placing the product on a bed, sofa, rug, or other similar surface. This product should not be placed in a built-in installation such as a bookcase or rack unless proper ventilation is provided or the manufacturer's instructions have been adhered to.

Power Sources This product should be operated only from the type of power source indicated on the marking label. If you are not sure of the type of power supply to your home, consult your product dealer or local power company. For products intended to operate from battery power, or other sources, refer to the operating instructions.

Grounding or Polarization This product may be equipped with a polarized alternating current line plug (a plug having one blade wider than the other). This plug will fit into the power outlet only one way. This is a safety feature. If you are unable to insert the plug fully into the outlet, try reversing the plug. If the plug should still fail to fit, contact your electrician to replace your obsolete outlet. **Do not defeat the safety purpose of the polarized plug.**

Power Cord Protection Power supply cords should be routed so that they are not likely to be walked on or pinched by items placed upon or against them, paying particular attention to cords at plugs, convenience receptacles, and the point where they exit from the product.

Outdoor Antenna Grounding When an outside antenna or cable system is connected to the product, be sure the antenna or cable system is grounded so as to provide some protection against voltage surges and built-up static charges. Article 810 of the National Electrical Code, ANSI/NFPA 70, provides information with regard to proper grounding of the mast and supporting structure, grounding of the lead-in wire to an antenna discharge unit, size of grounding conductors, location of antenna discharge unit, connection to grounding electrodes, and requirements for the grounding electrode.

Lightning For added protection for this product during a lightning storm, or when it is left unattended and unused for long periods of time, unplug it from the wall outlet and disconnect the antenna or cable system. This will prevent damage to the product due to lightning and power line surges.

Power Lines An outside antenna system should not be located in the vicinity of overhead power lines or other electric light or power circuits, or where it can fall into such power lines or circuits. When installing an outside antenna system, extreme care should be taken to keep from touching such power lines or circuits as contact with them might be fatal.

Overloading Do not overload wall outlets, extension cords, or integral convenience receptacles as this can result in risk of fire or electric shock.

Object and Liquid Entry Never push objects of any kind into this product through openings as they may touch dangerous voltage points or short-out parts that could result in a fire or electric shock. Never spill liquid of any kind on the product.

Heat The product should be placed away from heat sources such as radiators, heat registers, stoves, or any product that produces heat.

Servicing Do not attempt to service this product yourself as opening or removing covers may expose you to dangerous voltage or other hazards. Refer all servicing to qualified service personnel. Modification to the hardware or software without authorization by AdventistSat will result in voiding any warranty. Service assistance may be arranged by contacting AdventistSat technical support at 866-552-6882.

Damage Requiring Service Unplug this product from the wall outlet and refer servicing to qualified service personnel under the following conditions:

When the power supply cord or plug is damaged.

If liquid has been spilled, or objects have fallen into the product.

If the product has been exposed to rain or water.

If the product does not operate normally by following the operating instructions. Adjust only those controls that are covered by the operating instructions as an improper adjustment of other controls may result in damage and will often require extensive work by a qualified technician to restore the product to its normal operation.

If the product has been dropped or damaged in any way.

When the product exhibits a distinct change in performance, this indicates a need for service.

Replacement Parts When replacement parts are required, be sure the service technician has used replacement parts specified by the manufacturer or have the same characteristics as the original part. Unauthorized substitutions may result in fire, electric shock, or other hazards.

Safety Check Upon completion of any service or repairs to this product, ask the service technician to perform safety checks to determine that the product is in proper operating condition.

Site Survey

If you feel comfortable with drilling holes in the walls and/or roof of your home, climbing ladders, attaching wires to the utility ground according to NEC and local codes and following step-by-step instructions, you might consider installing your own system.



The satellite is located over 23,000 miles away and the installation does require precise tuning and a great deal of patience to correctly install. Have you recently installed a light switch, ceiling fan, basketball hoop and programmed a VCR? If not, this project might not be a good time to hone your mechanical and electrical skills!

Please contact AdventistSat 866-552-6882 if you would like to schedule a basic professional installation in the US and Canada. In Mexico call 800-727-1080.

Will a AdventistSat System work at your home? Before assembling any equipment it is important to verify that the installation location has a suitable area to safely and securely mount the satellite dish and have a clear line of site to receive the satellite signal. The satellite dish must be pointed directly at the satellite, with NO obstructions between the two. This means NO trees and NO buildings. Satellite signals will not pass through leaves, limbs, so consider future tree growth, house remodeling or additions and new construction in your area. Do not attempt to install the dish indoors!

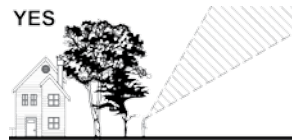

Where Is The Satellite?

Generally the dish will point towards the South, Southeast or Southwest. The satellite is located south of Texas and Mexico directly over the equator. That means if you live in Miami, you must have a clear line of sight to the Southwest; if you live in San Francisco, you must have a clear line to the Southeast.

Compass Azimuth Reading: _____

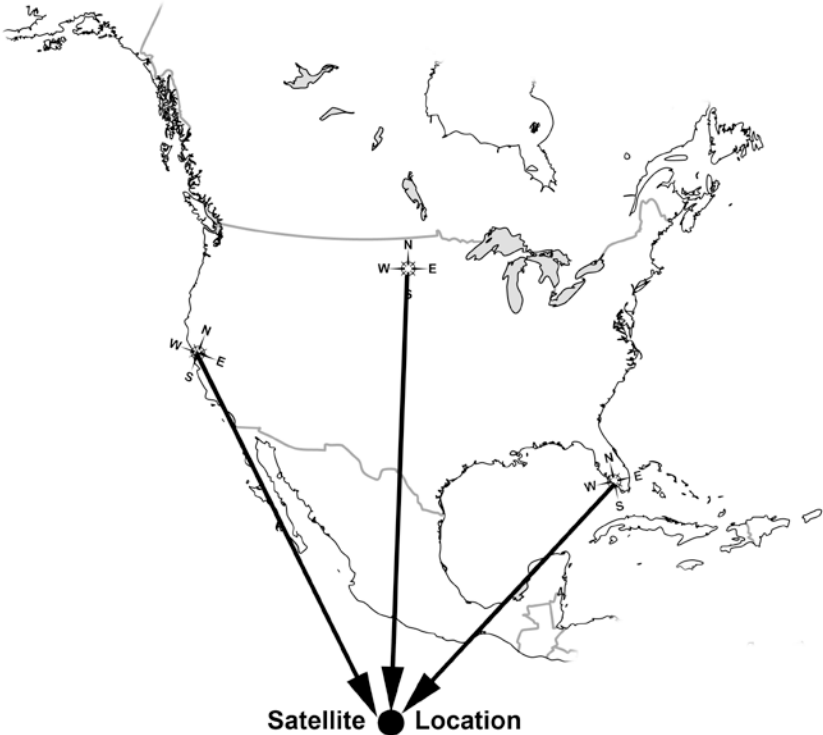

If you wish to schedule your own installation, visit <http://www.ftainstall.com>. This site will introduce you to local professionals and also laypersons who install Christian satellite systems as a ministry outreach.

How High Up in the Sky is the Satellite?

Depending on where you live, the satellite will be at an elevation angle between 30 and 60 degrees. Southern US point more toward 60 degrees; northern US point more toward 30 degrees. Northern Canada and Hawaiian elevations can be as low as 10 degrees, but Central American dishes will be aimed almost straight up!

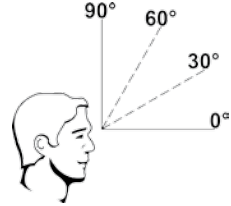

Dish Elevation Angle: _____

If installing West of Texas the satellite is located to the South East

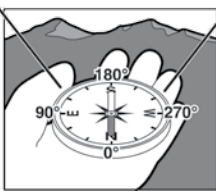

Compass

If installing East of Texas the satellite is located to the South West

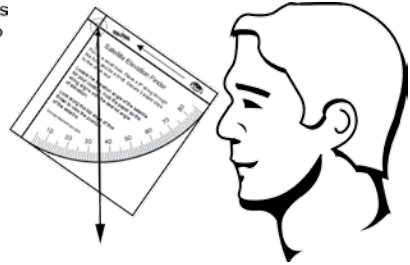

Elevation Angle Finder

Using the Site Check Tools

Using the aiming coordinates included with this system or found at <http://www.GeoSatFinder.com> along with a compass and the Site Check Angle Finder located on the last page of this manual, locate a suitable dish mounting position. While facing south, hold the compass level in the palm of your hand. With the red needle pointed exactly at North, reference the compass reading. Are there any obvious obstructions? If the line of sight appears clear, continue to the check the elevation angle. Sight along the top edge of the elevation angle finder with the weighted string registering the correct elevation angle. Is the line of sight clear with no branches, limbs or tall buildings?

Please note that the Elevation Angle Finder is only used for the site check and cannot be used to set the elevation angle of the dish. The elevation scale on the back of the dish is used for setting the correct elevation angle.

Dish Mounting Options

We recommend ground mounting the dish on a 1 5/8" heavy wall galvanized post set in cement. Attach a bolt or muffler clamp to the bottom of the post to prevent the post from twisting in the hardened cement. These items are readily available at any hardware store. Filling the post with a wet cement mixture will provide greater rigidity. The post must be perfectly plumb, level on all sides. Posts standing higher than 7 feet should be stabilized to prevent movement during high winds. The post should be installed in advance of the install as the cement can take 24 - 48 hours to set. Do not install the dish on a wooden 4" x 4" post or on a tree. The grain of the wood will twist during dry and rainy seasons causing the dish to swing off of the satellite causing reduced or loss of signal. Take proper precautions to protect the dish from being bumped during yard care or damaged by children at play.

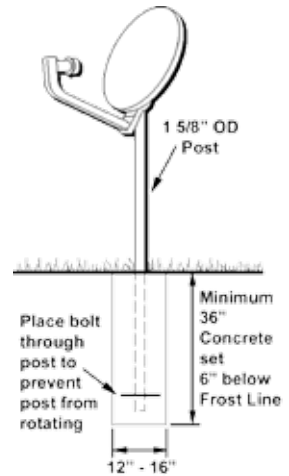

Ground Post Mount

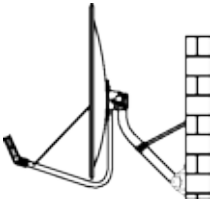

Wall Mount



Roof Mount

The AdventistSat system includes a heavy duty universal wall / roof post mount. This mount can be attached at almost any angle and provides a stable secure mount even in high wind regions if properly attached. If this universal post mount is used, the included tripod legs **MUST** be installed. The universal post will fail under moderate wind load if the tripod legs have not been installed to support the larger wind load area of a 36" dish. The dish and mount are designed to remain operational in winds up to 80+ mph and survive wind gusts over 110+ mph.

Failure to install the tripod legs will result in a charge back to the professional installer.

Dish Assembly

Once a suitable dish mounting location has been chosen it is time to set up the dish. Use the large cardboard shipping box as a working surface to prevent damage to the dish components during assembly. We recommend assembling the dish first and then installing on the post mount.



Important Note:

An assembled dish will not be accepted for refund.

Dish Reflector Accuracy

Before assembling the dish it is extremely important to verify that the reflector was not warped during shipping. Failure to check for dish warpage could lead to many frustrating hours of trying to locate the satellite.









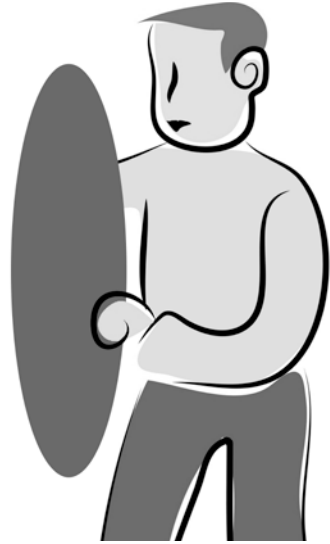





Find a perfectly flat surface such as a garage cement floor and lay the reflector face down. Are the edges of the reflector laying perfectly flat? If any area of the edge is raised by even an 1/8th of an inch reception of the satellite signal could be affected!

It is important to check the reflector for warping before assembly of the satellite dish.

If the reflector edges are not laying perfectly flat, pick up the dish by the edges like a steering wheel and quickly thrust the reflector away from your body while holding the edges of the dish. This action will cause the reflector to flex and it will spring back into the factory pressed shape. Lay the reflector face down and observe if the edges are now laying perfectly flat. If not, repeat the flexing process until the reflector edges are uniform and laying perfectly flat against the surface.



GEOSATpro 90cm Dish Hardware

Item	Quantity		Description	Size
1	6		Carriage Bolt	M6 - 12mm
2	2		Phillips Screw	M4 - 16m
3	2		Hex Nut	M4
4	12		Hex Nut 10mm	M6
5	2		Carriage Bolt	M6 - 20mm
6	1		Structural Bolt 10mm	M6 - 60mm
7	2		Elevator Bolt	M6 - 30mm
8	2		Washer	M6
A	4		Hex Flange Bolt	M6 - 12mm
B	1		Hex Nut 10mm	M6
C	1		Hex Tap Bolt	M6 - 90mm
D	1		Fastener Insert	

Please contact AdventistSat at 866-552-6882 if any of these parts are missing or damaged. Most replacement or damaged hardware items can be found at a local hardware supply store.

Attach the LNBF Arm to the Elevation Bracket. Assemble the Elevation Bracket and Post Clamp. Most installations in the US and Canada will use Elevation Scale A type assembly. Mexico installations will usually use Elevation Scale B assembly.



US and Canada

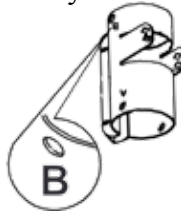

Mexico

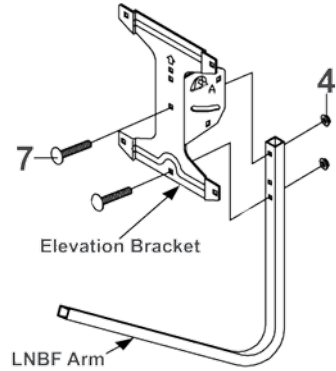

The Post Clamp has two holes drilled. One hole is stamped with an A and the other with a B. Assemble the Elevation Bracket to the Post Clamp using either the hole stamped A if the Dish Elevation Angle is between 20 - 50 degrees or the hole stamped B if the elevation angle is 50 – 90 degrees. The dish has been correctly assembled for Measuring the Dish Elevation Angle using the A Scale if an upside letter B is visible stamped on the Post Clamp. If an upside down letter A is visible on the Post Clamp, the dish has been assembled to use Scale B for measuring the Elevation Angle.

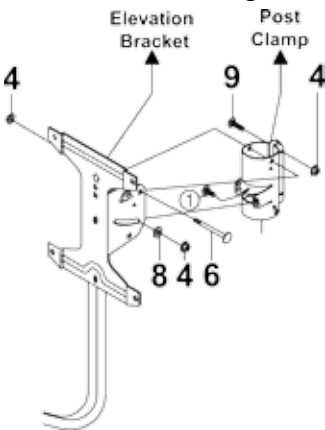

After verifying the reflector is not warped, mount to the Elevation Bracket and attach the two LNBF arm support arms.

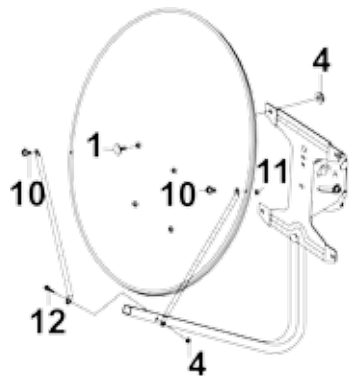

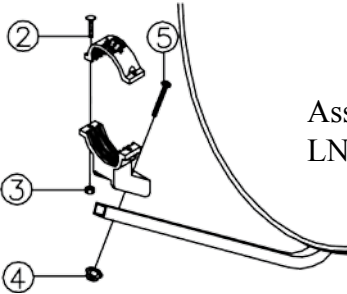

Assemble the LNBF Clamp and attach the LNBF clamp to the LNBF arm.

LNBF Rotation Angle: _____

Install the GEOSATpro Mini Bullet LNB into the LNBF Clamp. Slide the LNBF as far away from the reflector as possible so the tabs on the LNBF plastic housing touch the LNBF clamp. Rotate the LNBF in the circular clamp until the centering line on the top of the LNBF aligns with the LNBF Rotation specified in the aiming coordinates.



Standing in front of the dish looking towards the reflector, rotate the LNBF counter clockwise (left) for a positive (+) LNBF Rotation setting and Clockwise (right) for a negative (-) LNBF Rotation setting. The Rotation Angle is marked on the LNBF Clamp for Zero (0) and +/- 20 degree positions. Each mark on the clamp measures 5°. Example: If the aiming coordinates specify a LNBF Rotation of +13, set the pointer to a position between +10° and +15° counter clockwise (left). Tighten both clamp screws (2).



Example: Positive +20°

additional number of degrees necessary for setting the correct rotation angle. Example: If the Aiming Coordinates specify a LNBF Rotation of -30, estimate and add an additional 10° (two additional marks) and set the center pointer to a -30° clockwise position.

Optional: Universal Post

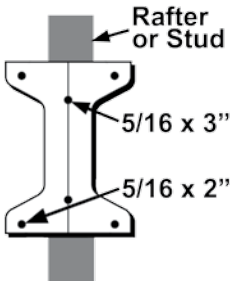

Mount the Universal Post Mount Foot Plate to a wall stud or roof rafter using two 5/16th x 3" lag bolts. Adding 5/16th x 2" lag bolts on the outer edges will increase stability.

To prevent water leakage, use the included silicone sealant or other waterproofing product on all wall or roof penetrations.

The Universal Post Mount can be assembled for roof or wall type installations. The post has slots for attaching to the Foot Plate on both ends of the tube. This allows the dish to be mounted with either a higher reach above a roof (as pictured) or outward reach away from a wall when using the slots on the opposite end of the post.

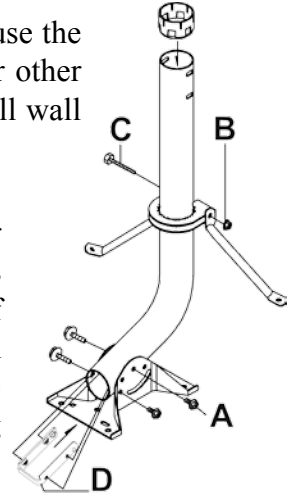

Level and Secure Post

Insert the Bubble Level into the top of the post. Be sure that it is seated level with the top edge of the post.

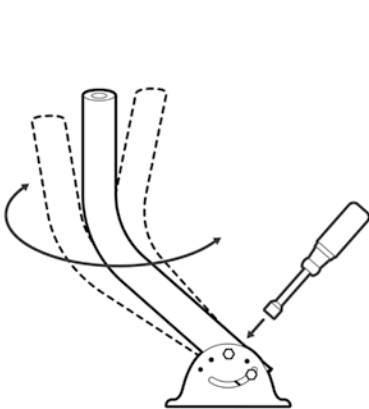

The unique slots in the post tube allows the post to be leveled in almost any installation position. Center the bubble in the level then tighten the 4 flange bolts to secure the post. It is very important to make sure that the post is perfectly plumb (level on all sides).

If the post is not exactly plumb, the elevation scale will not be accurate and it will be very difficult to locate the satellites and properly tune the dish for reliable reception.

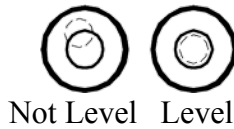

The most critical step to providing a stable mounting platform for the dish is the installation of the Tripod Support Legs. If the lag bolts cannot be secured directly into a stud or rafter, the legs should be secured into plywood sheeting with either a backing a toggle bolt or to a 2 x 4" that is lag bolted between the rafters or studs.

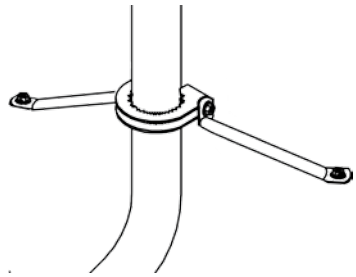

Remember to use silicone or other sealant on any roof or wall penetration. The legs are required to support the wind load on the universal post mount. Failure to install the tripod support legs will result in collapse of the post during moderate winds. The post is not designed to solely support the dish. If you hire a local installer, please be sure that the legs are installed.

AdventistSat will chargeback contracted professional installers if the Tripod Support Legs are not installed.

Dish Aiming

Elevation Angle

Place the assembled dish onto the post. Set the Dish Elevation to the angle provided on the cover of this manual. The pointer

for the elevation indicator is a white line that is visible through the elevation scale and is located near the edge of the elevation fastening nut.

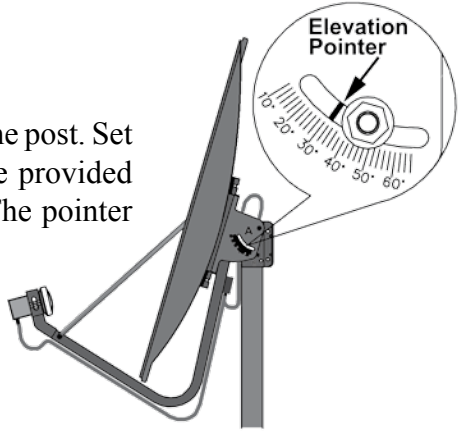

Semi-tighten the elevation fastening nuts to hold the dish in position. Do not tighten the fasteners for final setting at this time. Additional adjustment will be needed to locate and peak the satellite signal.

Do not grip the edges of the reflector to adjust the dish. Always hold the dish by the elevation bracket during elevation or azimuth (side-to-side) adjustments. Applying pressure to the reflector will affect the accuracy of the satellite signal reflection from the dish into the LNBF.

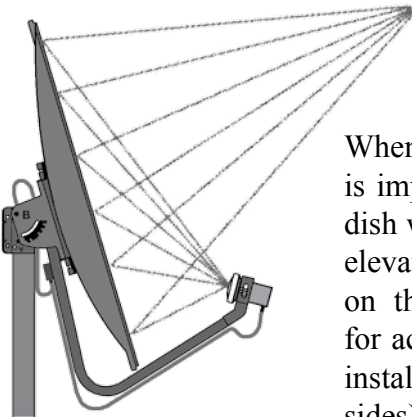

When setting the dish elevation angle it is important to note that the face of the dish will be aimed lower than the actual elevation angle to the satellite. The scale on the elevation bracket is calibrated for accurate aiming if the post has been installed perfectly plumb (leveled on all sides). The dish elevation angle cannot be set using an angle finder on the LNBF arm or on the face of the dish.

Compass Reading: Azimuth

In North America, the satellites are always located South of your location. To correctly aim the dish you must first accurately determine the exact compass reading angle (azimuth). Metals, electricity and other magnetic disturbances can cause the compass to point incorrectly. Compass readings should be made at least 10 feet in front of or behind the metal satellite dish and away from any large metal object such as metal buildings, air conditioners, vehicles, utility and power lines or electrical panels. Check compass reading several times to reduce install time and the need to hunt the entire southern sky for the satellite signal.

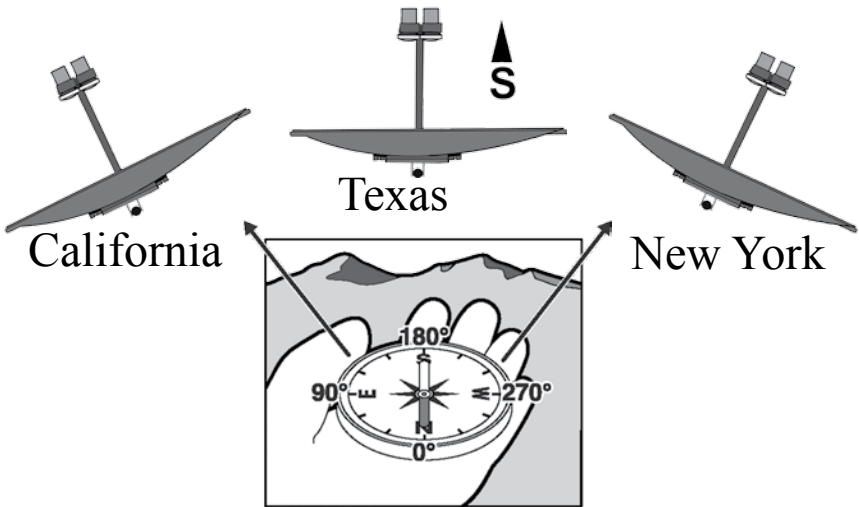

Example: Texas Magnetic Compass Reading 180 degrees.

Find a reference landmark on the distant horizon that corresponds to the compass reading provided on the cover of this manual. This landmark could be a utility pole, tree, or other stationary object. Installers often find it easier to aim the dish with a 10 - 20 foot string tied to the post and stretched out in front of the dish and aligned with the compass reading.

Move directly behind the dish and align the dish so that the LNBF arm is aimed directly at the reference landmark or in line with the string. Semi-tighten the post clamp nuts, but allow the dish to be just loose enough to be moved left or right by gripping the elevation bracket with applying light pressure.

Connect Receiver and TV

The easiest way to aim the satellite dish is to temporarily place the satellite receiver connected to a small television at the dish antenna mounting location.



CAUTION: DO NOT ATTEMPT TO OPERATE ELECTRONIC DEVICES IN AN UNSAFE LOCATION OR IN VIOLATION OF SAFEGUARDS PROVIDED IN THIS MANUAL OR ANY OTHER EQUIPMENT MANUAL PROVIDED WITH THIS ADVENTISTSAT SATELLITE SYSTEM.

Remove the satellite receiver and remote control from the packaging. Inspect the unit before operation. If any equipment is damaged or if you have any questions, please immediately contact AdventistSat at 866-552-6882.

Install the two included AAA batteries into the remote control. Connect a coaxial cable from the LNBF on the dish antenna to the LNB IN Digital port on the back of the satellite receiver. Do not connect Satellite dish to ANT INPUT, as this input is reserved for an outdoor antenna or cable TV connection.

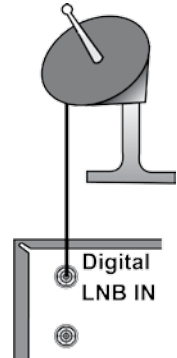

Finger-tighten all connections. Never use a wrench to tighten the LNBF and receiver connections as this will cause severe damage and void the warranty!

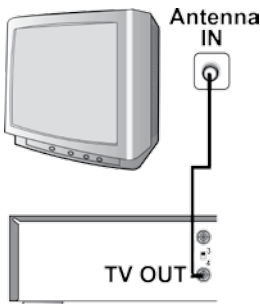

Set the channel 3/4 selection switch on the back of the satellite receiver to an unused channel in your area (usually channel 3). Plug the television power plug into a surge protected power strip. Turn the TV power on and set the channel to match this same channel.

Plug the satellite receiver's AC power plug to the same power strip. Power ON the Master Power Switch on back of the receiver. The receiver will power on and front panel will display information I.E. the channel number.

Activate Preprogrammed Channels

This equipment must be activated for the preprogrammed AdventistSat Television and Radio Services on satellite AMC4.

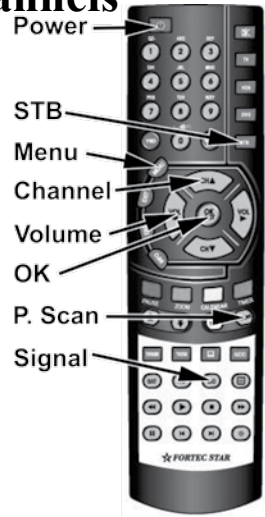

1. Press the **STB** button on the remote to control the Set Top Box with the universal remote control.
2. If required, press **VOL/Right** arrow to select an alternative language. *Skip this step for default English language selection.*

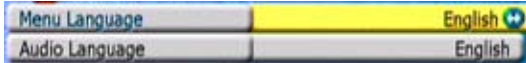

3. Press the **MENU** button to open the Installation screen.
4. Press **CH/UP** arrow to select **Factory Reset**.
5. Press **OK** to open the Factory Reset screen.

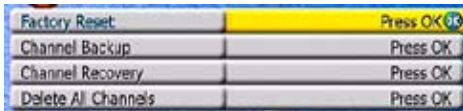
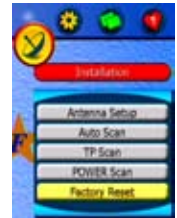

6. **Do not press OK!** Enter **1010** with the keypad.

7. When prompted with the on screen message “Do you want to load special data?”, select **YES** then press **OK**.

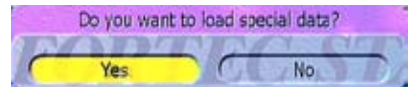

8. After the 2nd “Wait a Moment” on-screen prompt disappears the receiver will reset and display a banner across the bottom of the TV screen for Channel 1, the Hope Channel. The receiver is now activated.

Locate and Peak Signals

Press the CH/UP button to tune the receiver to 3ABN, Channel 3 (This is the strongest transponder on the satellite).

Press the SIG button on remote to activate the Signal Strength Level and Quality Install Screen with Signal Quality Tone Beeper. These screen shots show a receiver and LNBF are properly connected, but the dish is not aimed at the proper satellite.

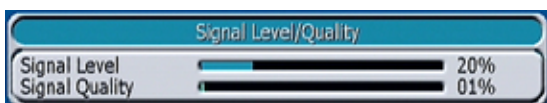

While you or an assistant observes the Signal Quality reading meter, slowly make a small left or right movement of the dish. If necessary, sweep the other direction until an indicator bar appears at any signal quality of 20% or better. The Signal Level will increase as the correct satellite is detected, but if the dish is aimed at an incorrect satellite, the signal quality meter will display a fluctuating low or no signal reading. *Note: Signal Level is not important at this time.*

If no Signal Quality is detected, increase or decrease the elevation by one degree and sweep again. The elevation may need to be adjusted +/- 5 degrees depending on the accuracy of the post leveling and mechanical tolerances. Move the dish very slowly to allow the receiver to process the signal information and update the strength displays. Sweep extremely slow as a movement of just 1/2 of a degree can result in a perfect or no signal. This process may need to be repeated many times to precisely aim and peak the quality of the signal.

Note: Setting the LNBF Rotation is extremely important! If the LNBF Rotation is not set to the approximate angle, the satellite signal might not be found.

When the dish is aimed correctly the “No Signal” indicator will disappear, programming will display and the Signal Quality will display a 50% or better quality level. These screen shots show a Quality Reading of a dish that is correctly aimed.

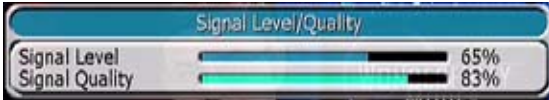

Once the correct satellite is located, make small adjustments in elevation and azimuth until maximum signal is indicated on the quality bar. The LNBF can also be slightly rotated within the LNBF clamp $\pm 5^\circ$ to optimize the channel's signal quality reading. Slightly loosen the two Phillips head screws that secure the LNBF clamp and slowly rotate the LNBF left or right. Peak for highest signal quality reading with the least amount of variations between the high and low signal quality levels. Signal Quality readings should be 50% or better to insure optimum picture and sound on the receiver. The higher the quality, the better the reception. If the signal quality is low the picture will break up into little squares and the sound will become garbled and choppy or will disappear completely!

Press CH/DOWN arrow to place the receiver on Hope Channel, Ch. 1 (This is a weaker transponder).

Verify the Quality reading is 50% or better. If not, peak Quality reading by fine tuning the dish angles and the LNBF rotation.

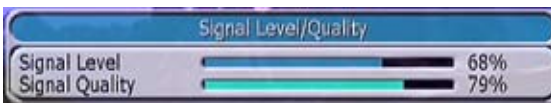

To verify that the dish is accurately aligned for reception of all Adventist channels, press the CH/UP arrow to surf through all of the preprogrammed TV and Radio channels and verify that the Signal Quality is 50% or better on all channels.

If the Signal Quality is below 50% on any of the channels, place the receiver on the channel with the lowest quality reading and make very small movements to the dish elevation and/or the dish panning side-to-side (azimuth) and /or LNBF rotation to peak the quality. If the Signal Quality reading remains low after attempting any combination of these adjustments, it is possible that the dish was not checked for warping or corrected before assembling the dish.

Record Signal Quality Sample Readings

CH #	Channel Name	Quality %	Quality %

Installation Notes:

Completing the Installation

Carefully route the coax cable from the dish to the ground block then to the satellite receiver. Secure all cables using appropriate cable clips and nylon zip ties. Avoid using wire staples as they can dimple or penetrate the cable and can cause loss of signal! Form drip loops and cable loops as needed to prevent

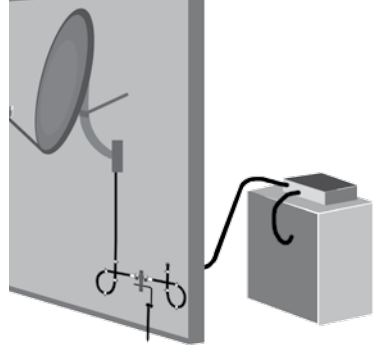

water from running down the cables and entering cable connection fittings or into wall penetrations. Remember to seal all exterior wall and/or roof holes with a quality sealant or silicone caulking.

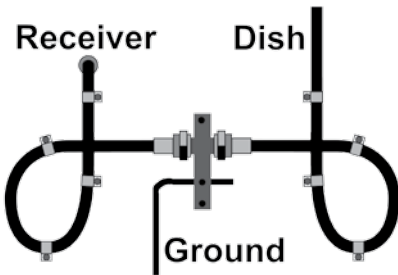

Install the grounding block and wire while observing all NEC, National Electrical Code and local codes. Connect the ground wire to the structure ground. If you are unsure of how to properly ground your satellite system, please consult with a local professional. Copies of the NEC are often available at your local library or online.

Important Notice: AdventistSat recommends that you DO NOT use existing coaxial cabling that has been pre-wired or previously used in your home. Often these cables are not rated for satellite applications or have splitters and other devices that are not compatible with a AdventistSat satellite system. Always connect the RG-6 type coax cable directly from the satellite dish LNBF through the grounding block and attach to the LNBF IN Digital connection on the rear of the Satellite Receiver.

Cable splitters or any other devices in the coax line may cause the satellite receiver to shut down or malfunction. Do not use any device in the coax line unless approved for satellite installation. Multiple receiver installations should use a multiple output LNBF to avoid programming conflicts between the receivers.

Basic Operation

Turn the satellite receiver ON/OFF using the Power button.

The STB button selects the satellite receiver as the device to be controlled by the remote.

Note: The power button lights each time a remote button is pressed.

Change channels by either entering the channel on the numeric keypad or by pressing CH/UP or CH/DOWN buttons.

The volume is adjusted by pressing the VOL/UP or VOL/DOWN buttons. *Note: Volume is also controlled by the TV. AdventistSat suggests that the satellite receiver volume be set at mid-level and use the TV to adjust the sound level.*

The TV/RADIO button select between viewing the satellite TV channels or listening to satellite radio services.

Channels may offer alternative audio translations or additional audio services. Press the AUDIO button to determine if additional audio selections are available. Press CH/UP or CH/DOWN to select alternative audio then the EXIT button. *Note: This selected source will be the default audio when this channel is selected.*

Press the PREVIEW button to display a multi-picture preview screen of available channels. Select 4, 9, 13 or 16 channel display. When the channels are displayed, select the desired channel to view using the CH/UP, CH/DOWN, VOL/LEFT or VOL/RIGHT arrow buttons. Press EXIT button to view.

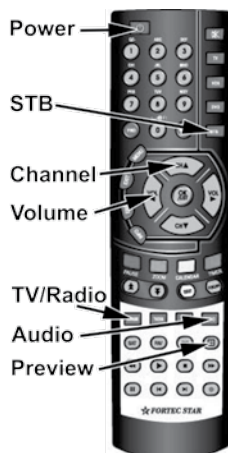

The receiver features many of the controls necessary for basic operation of the satellite system in case the remote is misplaced.

The Universal Remote Control can be programmed to control your TV, VCR and DVD equipment. Reference the Mercury II Owners Manual for programming information and codes.

FAQ – Frequently Asked Questions

Remote doesn't work but receiver front panel buttons may turn on/off and change channels. Press The STB button on the remote to control the Set Top Box. Check batteries, remote needs a clear line of sight to the receiver. Reset Master Power switch on rear of the receiver.

No lights on receiver. Check power plug make sure that it is plugged into a working electrical outlet. Reset Master Power switch.

Receiver displays 40% Signal Level, but no Quality on all channels. The dish might be pointed at the wrong satellite or there is an obstruction in the line of sight between the dish and the satellite. Mounting mast may have moved or is loose. Reset Master Power switch.

Meters display 0-1% signal level and 1-1% quality. Coax not connected from LNBF on dish to SAT INPUT on receiver. Dish not properly aimed. Bad coax, connectors or LNBF failure.

Picture breaks up into big blocks and the audio is garbled. The antenna might not be aimed correctly. Satellite view partially obstructed. Damaged coax or connections.

Satellite receiver has a channel number on front panel, but TV displays snow. Tune TV to channel 3 /4 or the AV input if using the RCA AV cables.

Local or cable TV channels are fuzzy and channel number is displayed on front panel. Turn off the satellite receiver when watching local or cable channels.

No audio on any satellite channels. Set satellite remote control audio up to 75% and use the TV volume control to adjust volume.

Picture breaks up during rain and snow. Heavy rain or clouds may affect the strength of the satellite signal. A properly installed dish will rarely lose signal during extreme weather. Snow or ice build up can interfere with the satellite signal. Mount the dish where snow can be gently brushed off. Dish covers and heaters are available for locations with regular ice and snow accumulations.

Satellite receiver displays “No Signal” only during very hot or cold weather. LNBF is aging or is affected by temperature extremes. Replace the LNBF.

Most of the channels have strong Signal Quality, but LLBN signal quality is poor or the receiver displays “No Signal”. LLBN has a weaker signal than the other Adventist channels and may display a low signal quality or no signal. Installations often need to be fine tuned to receive this weaker station. Place the receiver on the LLBN channel. Press the SIG key and make slight adjustments to the antenna elevation, azimuth and the LNBF rotation and distance from the reflector to peak the quality.

I only receive either the TV or the Radio Channels. How do I switch between these services? Press the TV/Radio button on the lower left corner of the remote control. This button toggles between the TV and Radio services available.

Are more channels available? Many more channels are available for viewing on this and other satellites. This receiver is capable of automatically programming these additional TV and Radio services. Many free national and international services are available. Do this at your own risk, as AdventistSat will only provide the warranty free technical support for the reception of the AdventistSat programming.

Scanning the Satellite for Additional Channels (optional)

1. Press MENU on the remote, verify that the receiver is in the Installation Menu. If not, VOL/RIGHT arrow to enter the Installation Menu.
2. Select Power Scan and press OK.
3. Select Satellite AMC4
4. Highlight Mode and change setting to Scan FTA
5. Highlight Start Scan press the OK to begin satellite scan. This process will take approximately 10 minutes
6. After the Scanning is complete, select YES to save the found channels
7. Press EXIT on the remote to begin viewing channels.

Do not call to activate programming; all channels are free to air and available with no monthly charge. The receiver assigns channel numbers while scanning; therefore, no uniform channel line-up will be available after a scan is performed.

Connection Examples

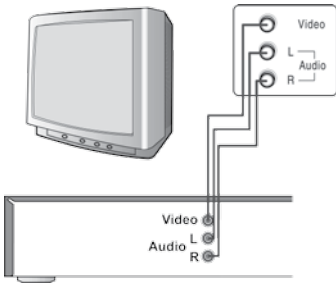

Audio / Video RCA

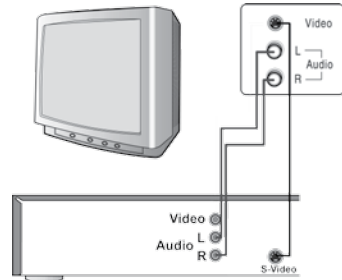

S-Video / Audio RCA

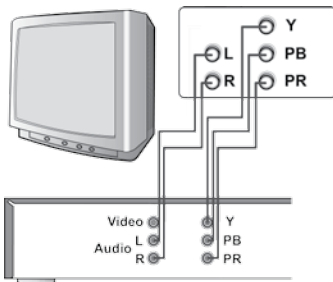

Component Video / Audio RCA

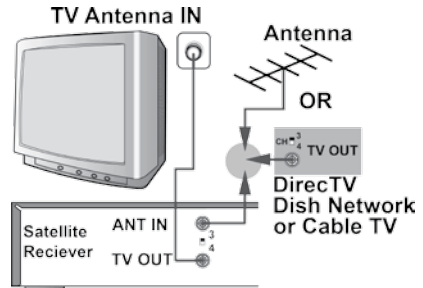

Cable, DirecTV, Dish or Antenna

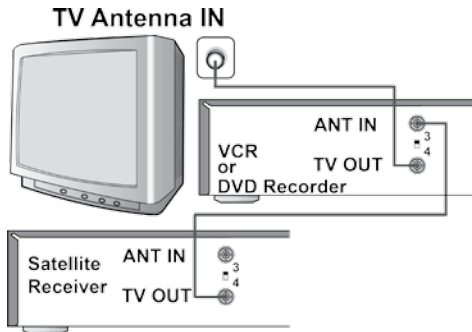

VCR or DVD Recorder

Please consult the owners manual provided with TV, VCR or other device that will be connected to the AdventistSat satellite receiver. The manual will include important connection and operational information. Please contact AdventistSat technical support for assistance in connecting the receiver to a television. Questions regarding the connection to any other equipment should be directed to the manufacturer of that device.

Accessories

* prices in US Dollar

AdventistSat carries a large selection of satellite accessories and replacement items. Please call 866-552-6882 or www.adventistsat.com for additional items or to place an order.



Glorystar Satellite System
Over 50 Christian Channels
\$199 + Shipping



Extra Mercury II Receiver
Replacement or Extra Room



Non-Penetrating Roof Mount
No Holes or Temporary



Satellite Finder Meter
Installs Faster, Easier



AC Surge Protector
Protect Your Investment



Single LNBF



Dual LNBF
One Dish w/multiple Receivers



Dish 1.2 Meter
Reliable Fringe Area Reception



RF Remote Extender
Change Channels from 2nd Room



Universal Remote
Mercury Replacement



RG6 Coax Cable 3'
Connect VCR or to Splitter



Signal Line Amplifier
Long Cable Runs



S-Video Cable
Better Quality Picture



Splitter for 2 TV Viewing
Low Cost 2 Room Viewing

Two Year Limited Warranty

AdventistSat Satellite Systems are guaranteed to be free of defects in materials and workmanship under normal use for a period of 12 months from the date of Sales Invoice by the original purchaser. Annual warranty extension and telephone technical support is available for a \$19.95 fee.

AdventistSat agrees to repair or replace the unit at no charge within the warranty period, provided that the item is delivered to a AdventistSat service center in the original packaging and appropriately protected and packaged for shipment.

The warranty does not cover damage due to lightning, flood, fire, act of God, electrical surge, accident, misuse, abuse, negligence, modification of hardware, installation of software, improper operation, installation, or maintenance.

The warranty remedies presented here are exclusive and in lieu of all other expressed or implied warranties. No other representations or claims shall bind or obligate AdventistSat in any way. Any warranty applicable to this product is limited to the period described above. In no event will AdventistSat be liable for any special, incidental, or consequential damages, loss of revenues, cost of replacement goods, cost of professional services, or installer fees resulting from the use or malfunction of these products or to the equipment systems on which they are used.

Return, Repair and Exchange Policy

1. Call AdventistSat Customer Service at 866-552-6882 for an RMA number (Return Merchandise Authorization) before returning any merchandise.

2. Equipment must be properly protected and packaged to prevent damage in transit. The retail display box provided with the equipment is not suitable to use as a shipping container. Write the RMA number on the outside of each box near the mailing address.

3. All returned equipment must include a copy of the original Sales Invoice or the name, address, along with the RMA number and a description of the reason the equipment is being returned. AdventistSat will not be responsible for any loss or damages incurred while in transit for such returned merchandise.

4. Ship authorized RMA Merchandise to:

AdventistSat Satellite Systems
8801 Washington Blvd., Suite 101
Roseville, CA 95678

5. Warranty repair merchandise must be received within the 24 months from the date of Sales Invoice. Merchandise will be evaluated and tested for manufacturing defect or faulty workmanship. Problem-free merchandise or problems caused by improper settings or operation error may be charged a \$35 bench fee plus shipping charges. All returned merchandise for refund or exchange must be received by AdventistSat within 30 days of the original date of delivery. Equipment will be accepted for return if it is unassembled and in like new condition with original packaging and accessories. Refunds, exchanges or refused shipments are subject to a 20% restocking fee plus shipping charges.

6. AdventistSat reserves the right to refuse any returned merchandise if the equipment is returned without an RMA, not sold by AdventistSat or its authorized distributors, found to have hardware / software modification or used in a manner that voids the manufacturers warranty.

Quick Guide for Professional Installers

This is a summary of the installation process. This section is designed for use ONLY by the experienced professional installer.

AdventistSat equipment is preprogrammed to receive all Adventist Television and Radio Services on satellite AMC4. Follow these steps to activate the preprogrammed channels.

Activate Preprogrammed Channels

1. Connect the satellite receiver **TV OUT** to the television set **Antenna IN**. Place the **Output Selector Switch** on the back of the receiver to Channel 3 or 4 and select the same channel on the television set. Power **ON** both the satellite receiver and the television set.

2. Press the **STB** button on the remote to control the satellite receiver with the universal programmable remote control.

3. If needed, press the **VOL/RIGHT** arrow button to select an alternative language. *Skip this step for default English selection.*

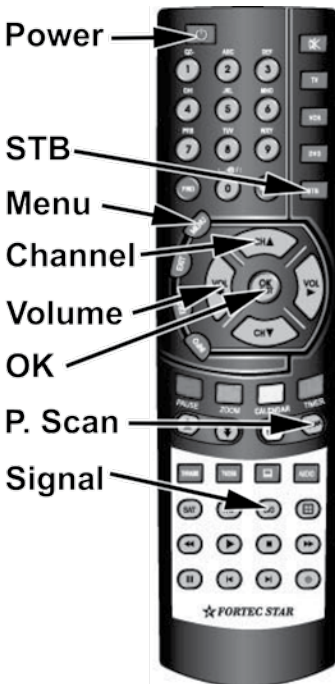
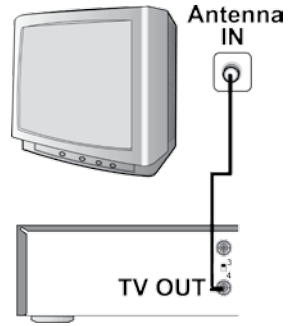

4. Press the **MENU** button.

5. Press the **CH/UP** arrow to select **Factory Reset**.

6. Press **OK**.

7. Enter **1010** with the numeric keypad.

8. When prompted with the onscreen message "Do you want to load special data?", select **YES** and press **OK**.

9. After the second "Wait a Moment" onscreen prompt disappears the receiver will reset and display a channel banner across the bottom of the screen for Channel 1, the Hope Channel.

10. The channel activation is complete.

Before assembling the satellite dish, lay the reflector on a flat surface. **Verify that the reflector has not been warped** in shipping. If the edges do not lie flat, hold the dish like a steering wheel and rapidly flex the reflector away from your body. Repeat if needed until the edges lay perfectly flat.

1. Perform a thorough site survey using the included dish aiming coordinates for AdventistSat Twin Satellite System. Verify line of site for AMC4 101w co-located at the DirecTV 101w location.
2. Install the dish on either the universal roof/wall mounting post or mounted on a steel post set in concrete. It is very important to have the post perfectly plumb before mounting the dish. Mast tripod support legs **MUST** be installed if the dish is mounted with the included universal post mount. **Failure to install the tripod support legs will result in a Charge Back to the contracted installer.**
3. Install the LNBF into LNBF clamp. The LNBF should be slid in the clamp away from the reflector. Align the LNBF centering marks with the LNBF rotation scale numbers on the LNBF clamp. Standing in front of the dish looking towards the reflector, a Positive (+) LNBF Rotation is counter clockwise (left), Negative (-) is clockwise (right). The LNBF clamp has marking for 0° , -20° and $+20^{\circ}$ degrees. Each mark is equal to 5° . If the aiming coordinates specify a rotation greater than 20° , estimate the additional number of degrees needed and set the LNBF rotation to the approximate angle.
5. The satellite receiver features very sensitive Strength and Quality meters to align the dish. Connect LNBF #1 output to the satellite receiver Digital LNB IN using either the 25' or 75' coax cable.
6. Tune the receiver to 3ABN Channel 3 (This is the strongest transponder on the satellite).

When using a Lacuna, SatHawk, BirDog or SatBuddy digital satellite location and identification meter, connect the LNBF to the meter and use data for standard LNB type, KU, AMC4, Horizontal and Vertical transponders. Peak for AMC4.

7. Press the SIG button on remote to activate the Signal Strength Level and Quality Install Screen with Signal Quality Tone Beeper.
8. Find the satellite and peak Signal Quality reading by setting the dish elevation and panning the dish side to side. *Note: Signal Level is not important at this time.* If no Signal Quality is detected, increase or decrease the elevation by one degree and sweep once again. The elevation may need to be adjusted up to +/- 5 degrees depending on the accuracy of the post leveling and mechanical tolerances. Slightly rotate the LNBF to peak for the highest signal quality. Signal Quality needs to be at least 50% + on this channel.
9. Press CH/DOWN arrow to place the receiver on Hope Channel, Ch. 1 (This is a weaker transponder).
10. Verify the Quality reading is 50% +. If not, peak Quality reading by fine tuning the dish angles and the LNBF rotation.
11. Press SIG key to remove display. Installation is complete!

Installer Tip: If you are having trouble locating the satellites, remove the AdventistSat LNBFs from the clamp and install a DirecTV LNBF into the LNBF clamp. Locate the DirecTV 101w satellite with a meter or DirecTV receiver. Replace the AdventistSat LNBF into the clamp. The Dish is now roughly aimed and will only require fine tuning for optimal reception of the linear satellite.



Cut Here

FOLD HERE

**Site Check Tool
Satellite Elevation Finder**

NOTE: This Angle Finder is to be used only for site checks. It cannot be used on the dish to set the Dish Elevation Angle.

Punch a small hole. Place an 8" string through the hole and tie a knot. Tie a paper clip or other weight to the other end of the string. Allow the weighted string to hang freely across the scale pointing at the Dish Elevation Angle provided with this Satellite system or calculated at <http://www.GeoSatFinder.com>

Sight along the top edge of this Elevation Finder. This is how high the satellite is located in the sky.

Are tree limbs or other objects blocking a clear view of the satellite? If so, you will need to site check another location to install the dish.

© Satellite AV, LLC 2006

FOLD HERE